



**UNIPOINT CONTROL
SYSTEM**

Setup Guide

Polyaire™ Pty Ltd

**11-13 White Road
GEPPS CROSS
South Australia, 5094
Tel: (08) 8349 8466
Fax: (08) 8349 8446
www.polyaire.com.au**

CONTENTS

Features	1
Application	1
Components	2
Configuration	3
Installation	5
Zone Address and Allocation	9
Recommended Commissioning Procedure	10
1. Initiating and Exit Setting Process	10
2. Room Temperature Sensor	10
3. Number of Zones in the System	10
4. Supply Air Safety High & Low Limits	11
5. Spill/Bypass Air Setpoint	11
6. Naming Zones	13
7. Damper on/off Test	13
Information Sheet	14
Trouble Shooting Guide	15
Specifications	16

Liability

Please read the instructions before installing this Zonemaster Zoning Control System. Polyaire Pty Ltd does not accept any responsibility for loss or damage that may occur as a result of the installation of this Zoning Control System.

FEATURES

- Manual and time programmable zone on/off control.
- Expandable up to 8 zones based on a serial control bus.
- Each zone has a unique address selected by a DIP switch.
- LCD indicator for zone status and parameter display.
- Room temperature display using an on-board sensor.
- Real time clock with battery backup.
- 5-1-1 zone on/off time programs.
- Personalised zone labelling.
- Auto spill/bypass --- the designated zones/bypass are forced open when all zones are turned off.
- Safety system --- Opens all dampers if the supply air temperature is less than low limit or more than high limit.
- All zones automatically return their original on/off state once power up.

APPLICATION

Zonemaster UniPoint control system is a fully featured and engineered system that is well suited to all ducted, reverse cycle, heating and evaporative air conditioning system for light commercial, residential or apartment applications.

COMPONENTS



1) Touchpad

User can input control commands from the touchpad to turn a zone on or off. The LCD on the touchpad displays clock, room temperature and zone status.



2) Damper Controller

Damper controller receives control signal from the touchpad to turn on/off the zone. Each damper controller has a unique address identified by the touchpad.



3) Motorised Damper

Motorised damper drives the blade of the damper to turn on/off the air from ducting to a zone.



4) Bridge Cable

Bridge cable connects the damper controller and the motorised damper together.



5) Supply Air Sensor

Supply air sensor measures the temperature of the supply air for safety purpose.



6) Power Supply

The 24VAC transformer provides power to the touchpad and damper controllers.



7) Battery

3.6 V rechargeable battery for real time clock backup.



8) Double Adaptor (Optional)

It can be used to connect the touchpad with the control bus to shorten the length of the cable.



9) Mounting Bracket

CONFIGURATION

The cabling of the Zonemaster UniPoint is straightforward. One connection is to connect the touchpad, dampers and power supply in series via a control bus as shown on Figure 1.

Figure 2 shows another connection in which a double adaptor is used to connect the touchpad in the middle of the control bus to save cables. The installation procedure is detailed as follows.

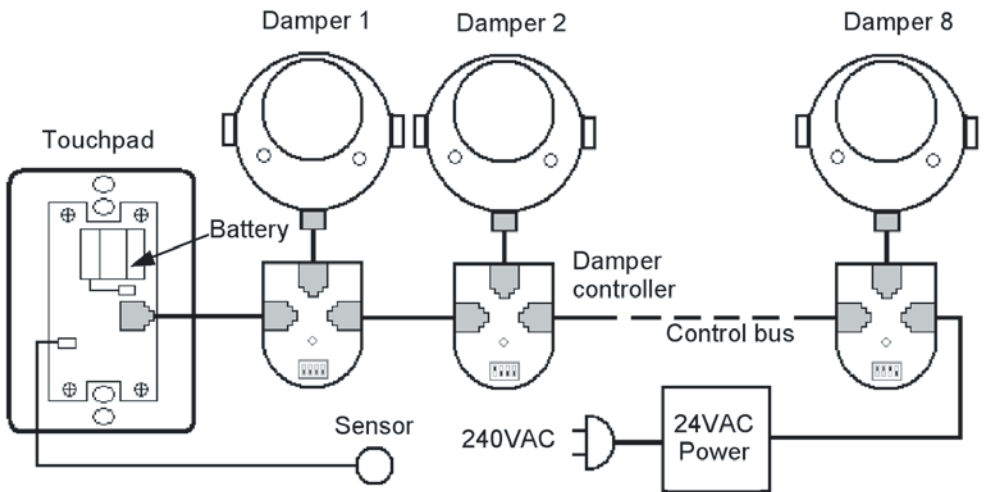

Figure 1. Wiring diagram 1

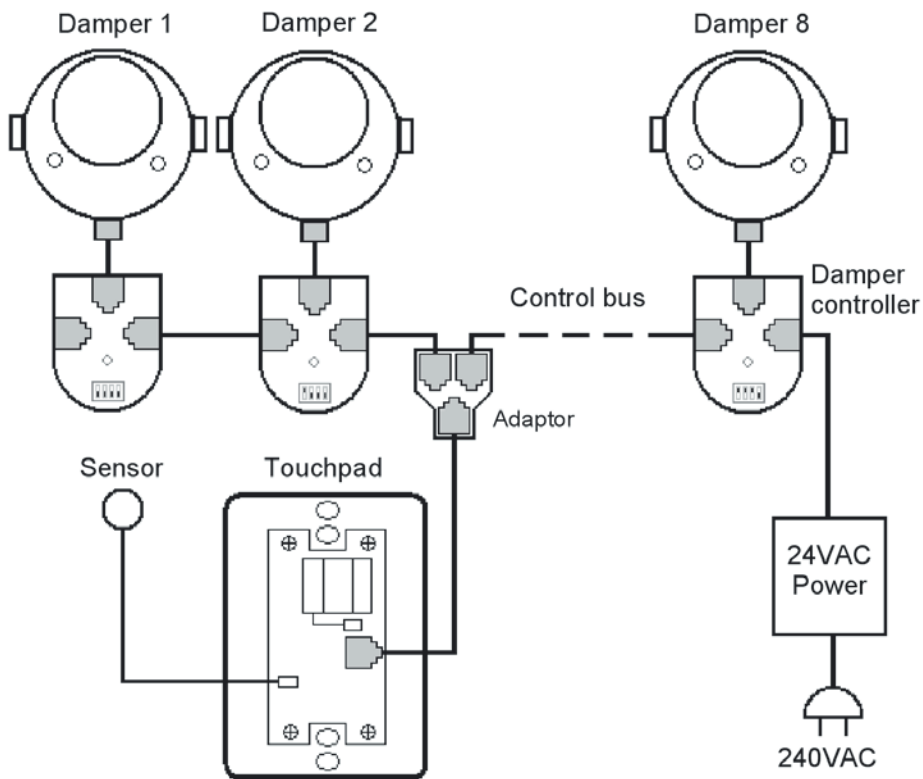
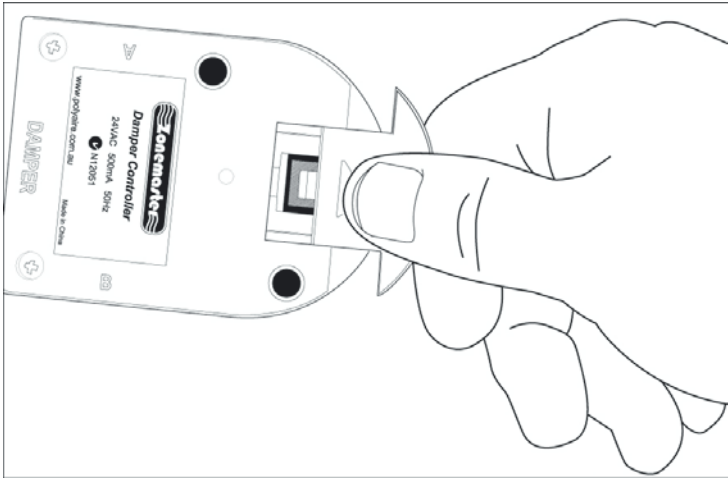

Figure 2. Wiring diagram 2

INSTALLATION

- 1) Take off the small cover on the top of the damper controller.



- 2) **Allocate and set unique addresses to all zones with consideration of spill privileges for the zones.** Please refer to the Zone Address section for details. Please note that bypass damper has a special address as shown in Figure 3.

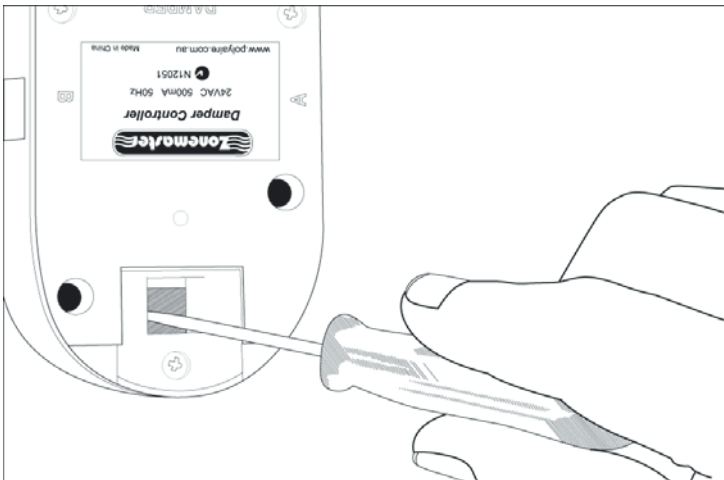

- 3) Mount the damper controller on the top of the motorised damper, or installed elsewhere close to the motorised damper. Plug the bridge cable into the damper port on the damper controller and the motor.

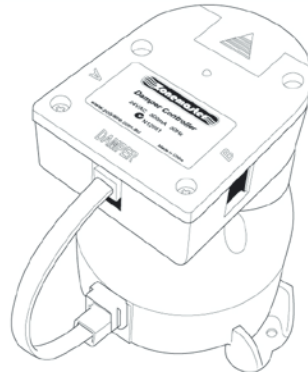

Warning - Do not plug the damper controller into any other motorised damper except a Polyaire authorised one.

- 4) Apply the power to the transformer by plugging in the transformer into the 240VAC power outlet.
- 5) Plug the 24VAC power supply into the socket on the last damper controller at the end of the control bus. The LED light on the damper controller should be on. Otherwise, check the power supply and the connection.

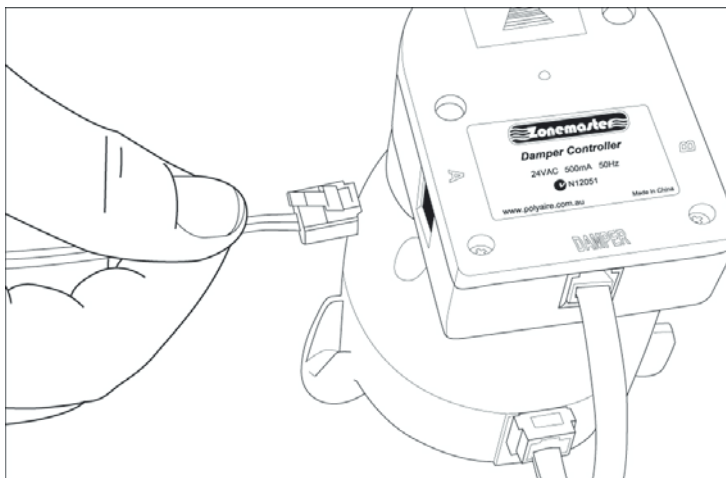

- 6) Use a pre-tested cable to connect the last damper controller with the next one. The LED light on the next damper controller should also be on. If not, check the cable and the connection.

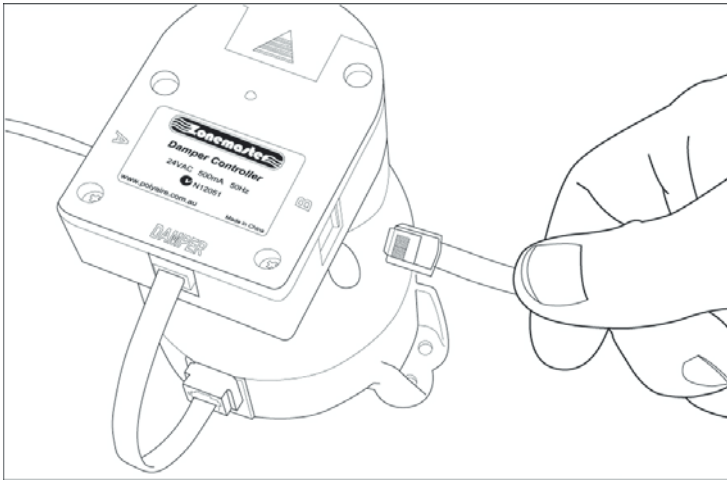

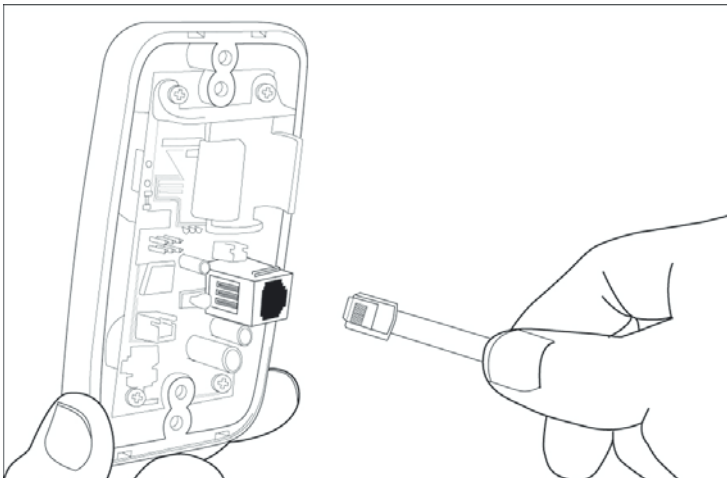

- 7) Repeat the step 6) until all damper controllers are connected together in series and all LED lights are on.
- 8) Use another pre-tested cable to connect the touchpad with the first damper controller as shown in Figure 1 or in the middle of the control bus via a double adaptor as shown in Figure 2.

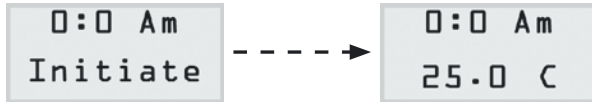

- 9) Check all the LED lights on the damper controllers again. If some of the lights are off, the cable to the first off-light damper controller could be crossed over. Check and replace it.
- 10) Repeat step 9) until all of the lights are on and the LCD screen on the touchpad shows clock time and the room temperature where the touchpad is located after showing "initiate" on the second line for about 15 seconds.



- 11) Hold down both  and  buttons on the touchpad for about 5 seconds to enter the setting mode (refer to next section). Check all the LED lights on the damper controllers again. All of the LED lights must be flashing in one-second interval. Otherwise, check the cable and the connection.
- 12) Turn off the power and disconnect the touchpad.
- 13) Position the touchpad at the right place. Ideally, its position is approximate 1.6M off the floor on the wall. Fit the cable through the wall cavity and connect the touchpad again.
- 14) Apply the power again to the transformer. The LCD should show clock time and temperature. If not, check the cable.
- 15) Mount the supply air sensor in the supply air duct upstream the motorised damper.

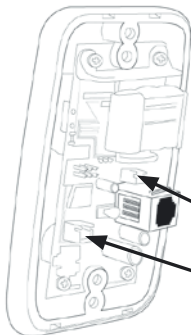

- 16) Fit the sensor cable through the wall cavity and plug into the socket on the back of the touchpad.
- 17) Connect the battery by plugging into the socket on the back of the touchpad.

battery
sensor

18) Mount the touchpad onto the bracket in the wall cavity.



Please note that the touchpad should not be exposed to direct sunlight and other heat sources.

ZONE ADDRESS AND ALLOCATION

Each damper should have a unique address in the serial control bus to be identified by the touchpad. This address is configured by a standard 4-way DIP switch inside the damper controller to provide 8 unique normal zone damper addresses and a special address for the bypass damper. All damper addresses can be set as shown in Figure 3.

When allocating address to each zone in spill mode, it is strongly recommended to give lower addresses to those zones that have higher spill privileges. The lower the address, the higher the spill privilege the zone has. When the spill setpoint is reached, the touchpad instructs zone 1 to open as spill. If the first spill zone cannot satisfy the spill air control, the zone 2 will be instructed to open to spill excess air. This process will continue until the spill air setpoint is satisfied in the system. Such a spill air control strategy implemented in the Zonemaster UniPoint control system requires the installer to allocate the zone 1 near the return air grilles.

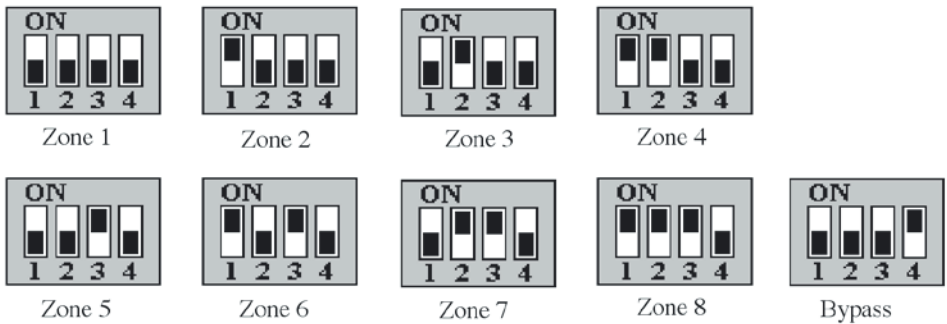



Figure 3. Damper address setting

RECOMMENDED COMMISSIONING PROCEDURE

1. Initiating and Exit Setting Process

The Zonemaster UniPoint has several parameters that must be set in the commissioning stage.

Setting

- 1) Hold down both  and  buttons for about 5 seconds until the LCD displays '**Setting**' on the top line of the LCD screen.

10:30 Am

25.0°C

- 2) At the setting mode, pressing  button at any time will return to the normal operation mode.



2. Room Temperature Sensor

The touchpad has an onboard sensor to measure the temperature of the room for indication purpose. The sensor can be calibrated by the parameter and provides more accurate temperature display.

- 1) Using an accurate probe to measure the temperature of the area you want to calibrate and record the value.

Sensor

24.5°C



- 2) At the setting mode, press  button until the LCD displays the '**Sensor**' screen.
- 3) Press  or  button to adjust the displayed value to the record value.

3. Number of Zones in the System

For the purpose of zone status display and spill/bypass zone calculation, the controller needs to know the total number of on/off zones in the system. Its factory default value is 8.

O/F Zone

Z1-Z8

- 1) At the setting mode, press  button until the LCD displays the '**O/F Zone**' screen.
- 2) Press  or  button to adjust the number of zones to the total number of the zones installed. It can be selected from 1 (show '**Zone 1**') to 8 (show '**Z1—Z8**').

4. Supply Air Safety High & Low Limits

10:30 Am
Safety



For safety reasons, the system monitors the supply air temperature closely.

If the temperature moves outside of the limits, all dampers in the system are forced open and the LCD displays '**Safety**' on screen.

The factory default supply air safety high & low limits are 60°C and 5°C respectively and safety control is disabled.



H limit
60.0°C

1) At the setting mode, press  button until the LCD displays the '**H_limit**' screen.

2) Press  or  button to change the high limit to the desired value. The adjustable range of the high limit is from 45°C to 75°C.

L limit
5.0°C

3) Press  button once again, the LCD screen will display the '**L_Limit**'.

4) Press  or  button to change the low limit to the desired value. The adjustable range of the low limit is from 0°C to 15°C.

If the customer does not want the safety function, the supply air sensor is not needed to be installed. The safety H_limit and L-limit MUST be disabled by pressing  button during the setup.

5. Spill/Bypass Air Setpoint

Spill/Bypass air is primarily used to relieve duct pressure for the safety of the ducting. Such a control is achieved by comparing the system requirement with a setpoint. The factory default is in spill mode and the setpoint is 30% of the total number of zones, which is equivalent to 30% of the total airflow across the fan coil.

Spill mode uses the zones with the lowest addresses in the system as spill zones that will be automatically forced to open if the total number of open zones is less than its setpoint.

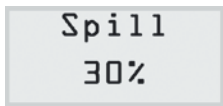

In bypass mode, a bypass damper is used to return the air directly to the duct if the total number of open zones is less than its setpoint. The bypass damper is also serially connected with other dampers and has a special address as mentioned before.

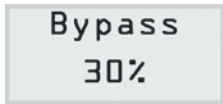

1) At the setting mode, press  button until the LCD displays the 'Spill' or 'Bypass' screen.

2) Press  button to select spill or bypass mode.











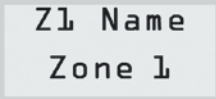

3) Press  and  button to change the spill/bypass setpoint to its desired value. The adjustable range is from 0% to 50%.

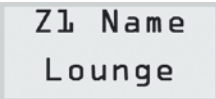

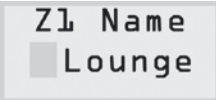
If no spill or bypass control is required in the system, the setpoint MUST be set to 0.

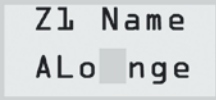
6. Naming Zones

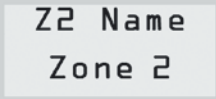
The name of a zone is called '**Zone_addr**'. For example, zone 1, which has an address of 1, is called '**Zone_1**' on its factory default. The names can be customised as you prefer as follows:









- | | |
|---|---|
|  | 1) At setting mode, press  button until the LCD displays the first zone naming, for example, 'Z1 Name' on the top line of the LCD. The second line shows the current name of zone 1. |
|  | 2) Press  or  button to select one of the 27 preset zone names for the zone. |
|  | 3) To make changes to the preset selected name, press  button to move to the character that is flashing. |
|  | 4) Use  or  button to select the character from the list as desired. There are 26 alphabets in capital and normal case, 10 numbers and a space in the list. |
|  | 5) Press  button to select the next zone naming screen and follow steps 2 to 4 to customise the name of the zone. |

7. Damper on/off Test

- 1) Switch on the air conditioner.
- 2) Press  button to turn each of the zones on or off to check if the damper is correctly connected by feeling the air at the outlet. Refer to User's manual for the operation.

INFORMATION SHEET

The following zone table is designed to assist installation and commissioning.

Address	Default Name	Custom Name
	Zone_1	
	Zone_2	
	Zone_3	
	Zone_4	
	Zone_5	
	Zone_6	
	Zone_7	
	Zone_8	

Parameter	Default Value	Custom Value
O/F Zone	Z1—Z8	
High limit	disable/60 °C	
Low limit	Disable/5 °C	
Spill	Spill/30%	

TROUBLE SHOOTING GUIDE

Problem	Suggested Action
The LED light on the damper controller does not lit up after powering up.	<ul style="list-style-type: none">• Check the power supply.• Check the cable to and from this damper controller.• Check the connection between the cables and the controller.
Touchpad has nothing shown on LCD.	<ul style="list-style-type: none">• Check the power supply.• Check the cable and plug to the touchpad.
Touchpad display is not normal.	<ul style="list-style-type: none">• Disconnect the battery at first.• Reset the touchpad by turning off and turning on the power supply again. If the display is normal, plug in the battery again.
Dampers have no response when turning it on or off.	<ul style="list-style-type: none">• Check the damper controller and make sure that the LED lit up.• Check the damper address.• Check the cable to the damper controller.
Some zones cannot be turned off.	<ul style="list-style-type: none">• Check if it is spill zone (with lower address).• Check spill setpoint.
All zones open and touchpad display “safety”.	<ul style="list-style-type: none">• Check high & low limit setting.• Check and replace the supply air sensor.

Please contact distributors for any other problems not listed as above.

SPECIFICATIONS

Electrical Requirements

Power supply	24VAC \pm 10%
Line frequency	50 Hz

Components Power Consumption

Touchpad	0.5 VA
Damper controller	2.5 VA

Environmental Requirements

Operating temperature	0°C to 60°C
Altitude	0 to 2000 metres
Operating relative humidity	10% to 80%
Avoid static electricity hazards	
Avoid electromagnetic radiation sources	
Avoid dust contamination	
Avoid highly corrosive environments	

Touchpad

Power input	24VAC, 50Hz
Dimensions	78W x 118H x 13D

Damper Controller

Power input	24VAC, 50Hz
Dimensions	60W x 85H x 25D

Transformer

Input Voltage	240VAC, 50Hz
Output Voltage	24VAC, 50Hz
Wattage	24W

Supply Air Sensor NTC type, 10 k Ω at 25°C

Battery AAAM rechargeable battery, 3.6V

Control Bus 50 metres

